

The Yin-Yang of Matching: Part 2—Practical Matching Techniques

By Randy Rhea
Consultant to Agilent Technologies

The conclusion of this article covers transmission line matching networks, plus a discussion of how characteristics of the load affects matching bandwidth and the choice of network topologies

The Standard Quarter-Wavelength Transmission Line Transformer

A well-known distributed matching network is the quarter-wavelength long transmission line transformer. I will refer to this

network as a type 11. The characteristic impedance of this line is given by

$$Z_0 = \sqrt{R_s R_L} \quad (41)$$

For example, a 100 ohm load is matched to a 50 ohm source using a 90° line with characteristic impedance 70.71 ohms. The matchable space of the quarter-wavelength transformer is small, essentially only the real axis on the Smith chart. Nevertheless, it enjoys widespread use. A quarter-wavelength line is also used in filter design as an impedance inverter to convert series resonant circuits to parallel resonance, and vice versa [4].

The General Transmission Line Transformer

Perhaps less well-known is that a single series transmission line can match impedances not on the axis of reals. The matchable space of this type 12 network is plotted in Figure 9. The characteristic impedance of the series line is given by

$$Z_{12} = Z_0 \sqrt{\frac{1 + \rho_{\max}}{1 - \rho_{\max}}} \quad (42)$$

where

$$\rho_{load} = \frac{Z'_L - 1}{Z'_L + 1} \quad (43)$$

$$\rho_{\max} = \frac{(\text{Im}[\rho_{load}])^2}{\text{Re}[\rho_{load}]} + \text{Re}[\rho_{load}] \quad (44)$$

and the electrical length of the line is given by (see text)

$$\theta_{12} = \tan^{-1} \frac{\sqrt{4a^2 + b^2} - b}{2a} + 90^\circ \quad (45)$$

where

$$a = Z_{12} X_L \quad (46)$$

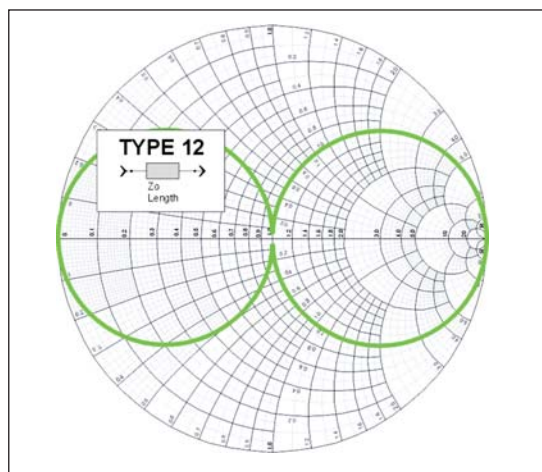

Figure 9 · By allowing line lengths other than 90°, the matchable impedance space for a single, series transmission line extends beyond the real axis.

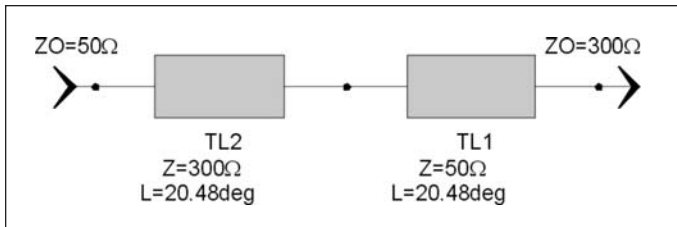

Figure 10 · Shortened double-section quarter-wave-length transformer for matching real impedances.

$$b = X_L^2 + R_L^2 - Z_{12}^2 \quad (47)$$

If the real part of the load impedance is less than the reference impedance and the load is capacitive, then 90° must be added to the length computed by Eq. 45. If the real part of the load impedance is less than the reference impedance and the load is inductive, then 90° must be subtracted from the computed length.

The Shortened Quarter-Wavelength Transformer

Another less well-known but useful adaptation of the quarter-wavelength transformer is the shortened, double-section transformer depicted in Figure 10. I will refer to this as type 13. Like the standard transformer, it is used to match real impedances. But the required length is shorter and it uses lines with characteristic impedance equal to the impedances being matched. These are both practical features in many applications.

Notice that the transmission line with characteristic impedance equal to the load is adjacent to the source. Both transmission lines have the same length. The maximum line length is 30° , and it decreases as the load impedance is much higher or lower than the source impedance.

With normalized load resistance R'_L , the line length is

$$\theta_{13} = \tan^{-1} \frac{1}{\sqrt{\frac{R_L'^2 + R_L' + 1}{R_L'}}} \quad (48)$$

For example, a 100 ohm resistive load is matched to 50 ohms using a single, 90° long line with a characteristic impedance of 70.7 ohms. With a cascade of 50 and 100 ohm lines, each is 28.13° long for a total length of 56.25° .

The Challenge

Since all complex loads are matchable by two element networks and sometimes a single transmission line, why is matching sometimes difficult? For loads with a large reflection coefficient, the element values may be difficult to realize. This is particularly true for distributed circuits. But more often the problem is bandwidth. A simple circuit

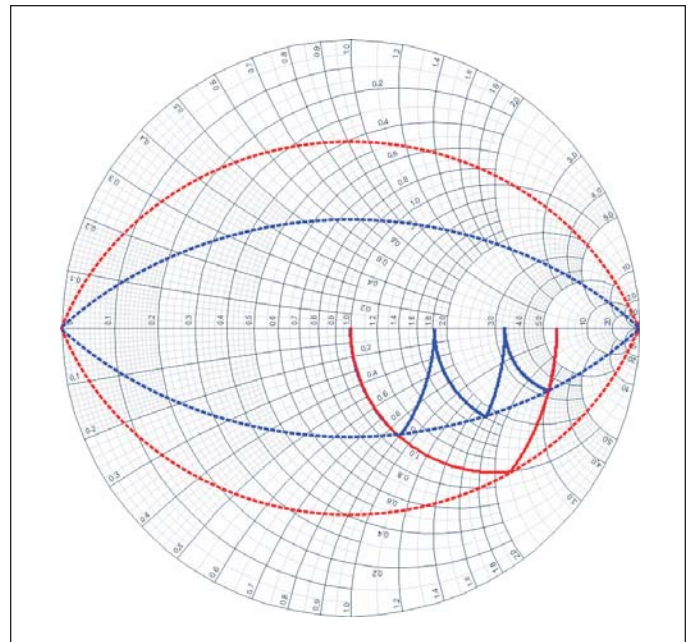

Figure 11 · Smith chart plot for a one section L-network (red) to match 300 ohms to 50 ohms and a three section L-network in blue. Also plotted are corresponding constant Q curves (dashed).

matches at a single frequency. Obtaining a good match over an extended frequency range may require many elements and finding values is very challenging. Before I cover this subject, let me introduce another fundamental concept.

Q of the Load

The term Q is used for several properties. Mastery of each is critical to understanding oscillators, filters, matching networks and other circuits [5]. One definition of *loaded* Q is the center frequency divided by the 3 dB bandwidth of a resonant circuit response. It is a finite value even if the circuit is built using components with infinite Q . Component Q , or *unloaded* Q , is a measure of component quality; the ratio of stored energy to dissipated energy in the component. It is as high as 200 for excellent inductors. But unloaded Q increases with physical size, so modern miniature inductors have much lower Q . Q of the load described in this section is yet a third definition of Q . I often feel engineers would be less confused if these properties were labeled Q , R and S . However, their definitions have similar roots.

Q of the load is a property of a complex termination. For series impedance it is given simply by

$$Q_{of\ load} = \frac{|X_L|}{R_L} \quad (49)$$

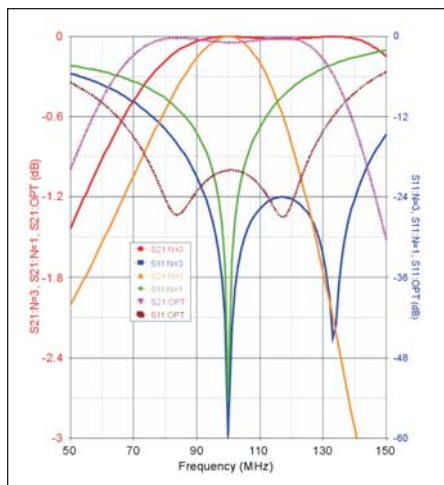

Figure 12 · Amplitude transmission responses for 300 ohm to 50 ohm matching L-networks.

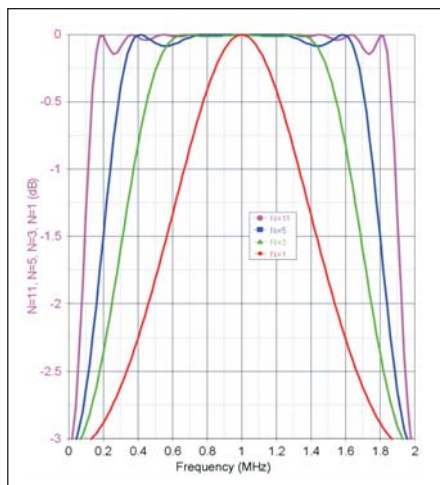

Figure 13 · Transmission amplitude responses for 50 to 300 ohm single-section (red), three-section (blue), five-section (green) and eleven-section transformers (magenta).

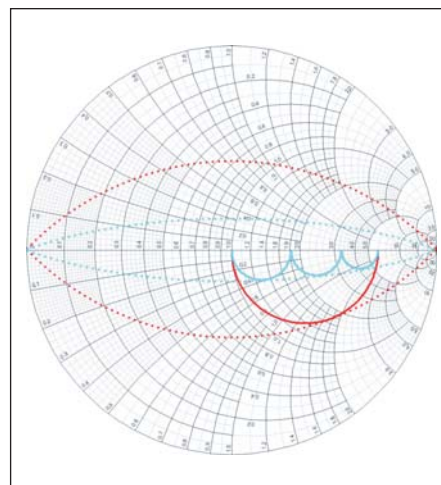

Figure 14 · Smith chart plot for a one-section quarter-wavelength transformer (red) and a three-section transformer (blue) to match 300 to 50 ohms.

and for parallel admittance it is

$$Q_{of\ load} = \frac{G_L}{|B_L|} \quad (50)$$

The dashed red lines in Figure 11 are arcs of constant Q of the load. These Q arcs pass through $X'_L = \pm 2.3$ where $R'_L = 1$ so $Q_{of\ load} = 2.3$. The dashed blue arcs mark a Q of 0.9 since they pass through $0.9+j1.0$ and $0.9-j1.0$. To understand the significance of Q arcs, consider the solid arcs in Figure 11.

Element Impedance Transforms Plotted on the Smith Chart

The solid red arc that begins at 300 ohms (6 normalized) on the real axis, right of center, is the resulting action at 100 MHz of a shunt 11.84 pF capacitor that transforms the 300 ohm load resistance to $50-j110$ ohms. The arc from this point to $50+j0$ is the result of a series inductor of 178.4 nH, or $+j110$ ohms. These arcs are not responses plotted versus frequency but rather the length of these arcs correspond to increasing values of the capacitor and inductor. These concepts are the basis of network design using the Smith chart [1, 2].

The red dashed Q arcs were drawn so they intersect the maximum extent of the solid L-network arcs, so the one-section L-network has a Q of 2.3. You can see that the arcs of the 3-section L-network remain closer to the real axis. The Q of the 3-section L-network is only 0.9.

Plotted in brown and green in Figure 12 are the transmission and return loss responses of the one section

L-network. Plotted in red and blue are the transmission and return loss responses of the three section L-network. The 15 dB return loss has a bandwidth of about 17% for the one-section L-network and about 59% for the 3-section L-network. The ratio of the bandwidths is $59/17 = 3.5$ and the ratio of the Q values is $3/0.9 = 3.3$. The exact relationship between the bandwidth and Q arcs depend on the return loss used to define the bandwidth. However, the relation is clear: matching networks with impedance arcs that remain closer to the real axis have better bandwidth.

Using impedance arcs is insightful when designing both lumped and distributed matching networks. But this process is increasingly ineffective when attempting to match multiple frequencies over a wide bandwidth. The blue arcs in Figure 11 were drawn for a single frequency, 100 MHz. The solid blue return loss response in Figure 12 reveals a near perfect match has been achieved at 100 MHz as expected since the last blue arc in Figure 11 ends at 50 ohms. But further examination of the blue trace in Figure 12 reveals that the response is not centered on 100 MHz, the design frequency. The dashed magenta and brown plots in Figure 12 are the result of optimizing all 6 element values to center the response on 100 MHz. When broad bandwidth is required, drawing arcs on a Smith chart, either with pencil and paper charts or by computer program, is cumbersome at best. Synthesis routines such as those in the Impedance Matching module of GENESYS are effective. Alternatively, optimization of an initial Smith chart design via computer simulation is effective for problems with well-behaved loads. This will be discussed in more detail later.

A Simple Algorithm for Multiple-Section Transformer

The bandwidth of a quarter-wavelength transmission line transformer decreases with loads higher or lower than the desired resistance. The bandwidth is about 22% for a ratio of 6:1 as with a 300 ohm load in a 50 ohm system. The bandwidth can be improved by cascading multiple quarter wavelength transmission line sections. Given in this section is a simple but effective algorithm for computing the required characteristic impedance for each section.

As introduced in Eq. 41, the characteristic impedance of a single section is the square root of the product of the source and load impedance. With the multiple-section transformer, each line uses the same formula between intermediate values of impedance, $Z_i(n)$. These intermediate values are computed to be a uniform geometric progression from the source to the load resistance.

$$Step = \left(\frac{R_L}{Z_0} \right)^{\frac{1}{N}} \quad (51)$$

where N is the number of sections. Then

$$Z_i(1) = Step \times Z_0 \quad (52)$$

$$Z_i(n) = Step \times Z_i(n-1) \Big|_{n=2}^N \quad (53)$$

$$Z_i(N) = R_L \quad (54)$$

The characteristic impedance of each section is

$$Z(n) = \sqrt{Z_i(n-1)Z_i(n)} \Big|_{n=1}^N \quad (55)$$

where $Z_i(0)$ is the source impedance.

The transmission amplitude responses for single, three, five and eleven section transformers are given in Figure 13. The response of this simple algorithm is somewhat Legendre in shape. The ripple is not equal across the passband and it increases with increasing N and increasing load reflection coefficient. The ripple bandwidth of the eleven-section transformer extends from about 0.16 to 1.8 MHz, more than a decade. Notice however a trend of diminishing return for an increasing number of sections. An Agilent GENESYS workspace for this N-section transformer also may be downloaded from the post "Matching Tutorial published in *High Frequency Electronics* magazine" at the Founder's Forum at www.eagleware.com.

In Figure 14, impedance arcs are plotted on a Smith chart for single and three section transformers. These plots suggest that an infinite number of sections would result in no departure from the real axis, the Q would be zero and the bandwidth infinite. In fact, this is the case.

Loads with only real and no reactive component may be matched over infinite bandwidth if an infinite number of sections are employed. For loads with a reactive component the bandwidth is limited.

Fano's Limit

In a classic paper, Fano [6] offers an elegant formula for predicting the relationship between the bandwidth and the best achievable reflection coefficient using a lossless, infinitely complex matching network. His formula involves $Q_{of\ load}$ introduced earlier.

$$\Gamma_{min} = e^{-\frac{\pi Q_{loaded}}{Q_{of\ load}}} \quad (56)$$

where Γ_{min} is the best match that is achievable over a bandwidth $F_{upper} - F_{lower}$.

$$Q_{loaded} = \frac{F_0}{F_{upper} - F_{lower}} \quad (57)$$

An algebraic derivative of Fano's equation is also helpful.

$$Q_{loaded} = \frac{-Q_{of\ load} \ln(\Gamma_{min})}{\pi} \quad (58)$$

An octave bandwidth is $Q_{loaded} = 1.5$. Using Eq. 2 we find a return loss of 15 dB is a reflection coefficient of 0.178. To achieve a 15 dB return loss would require $Q_{of\ load}$ less than 2.73. For another example, with a load of $300 + j300$, $Q_{of\ load} = 1.0$. The resulting $Q_{loaded} = 0.549$. Normalized to a center frequency of 1 MHz, a 15 dB return loss could be achieved from 0.089 to 1.911 MHz. I obtained a 15 dB return loss from 0.115 to 1.885, a loaded Q of 0.565, with a 26-element L-C network designed using a direct synthesis routine that is described later. A 26-element network is hardly practical, but it illustrates Fano's formula provides an absolute limit that is approached with significant effort. Fano's limit is used to discover if a solution is possible, thus avoiding effort on an unsolvable problem. This introduction to Fano's limit prepares us to consider broadband matching with reactive loads.

Reactance Absorption using Filters: Equal Resistance

I am often asked "How do you design a lowpass filter with unequal terminations?" Consider a lowpass filter between a 50 ohm source and a 300 ohm load. The definition of lowpass is a response from DC to an upper frequency limit. But, at low frequency the shunt capacitors

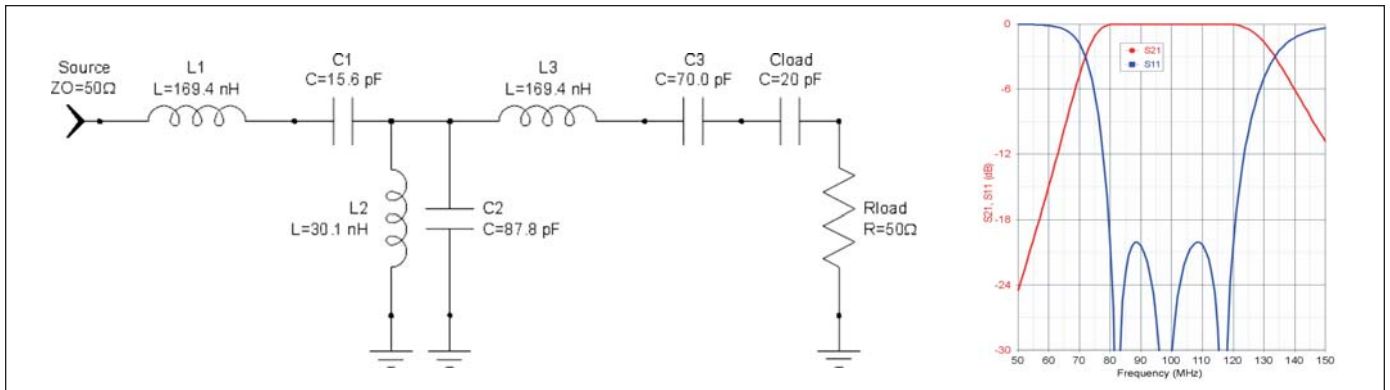

Figure 15 · Schematic and response of a bandpass filter used to match a 50 ohm load with 20 pF series capacitance.

become high impedance and they vanish, and the series inductors become low impedance and they vanish. So if the components effectively vanish, how can the network match 50 ohms to 300 ohms and have a low-loss response at low frequency? It can't! The solution is theoretically unrealizable. A match and maximum power transfer can be achieved over a limited bandwidth that does not extend to DC. The response is pseudo lowpass. The return loss and insertion loss at low frequency are the same values that would exist without the network with 50 ohms driving a 300 ohm termination as computed by Eqs. 2 and 4. The bandwidth degrades and the low-frequency insertion loss increases with increasing source/load resistance ratio.

However, a lowpass filter can match a reactive load up to the cutoff frequency if the load resistance equals the source resistance. Consider a complex load with 50 ohms in parallel with 20 pF capacitance. A standard lowpass filter with shunt 20 pF or higher capacitor at the output can absorb the load capacitance. The shunt capacitor in the lowpass is simply reduced by the value of the load capacitance. Likewise, if the load has series inductance, a lowpass filter with a series output inductor is used. A match is achieved from DC to a maximum frequency given by

$$F_{\max} = \frac{g}{bw \times 2\pi RC_{\text{shunt}}} \quad (59)$$

$$F_{\max} = \frac{gR}{bw \times 2\pi L_{\text{series}}} \quad (60)$$

where g is the lowpass prototype g -value adjacent to the load, C or L is the load capacitance or inductance, R is the load resistance and $bw = 1$. Increased reactor values may be absorbed by accepting higher passband ripple. g ranges from 1 for a 5th order Butterworth response to 2.13 for a 1 dB ripple Chebyshev. For example, $g = 1.15$ for a 0.1 dB ripple 5th order Chebyshev. 20 pF of shunt capacitance is matched up to 183 MHz using this filter. The g -value also increases with increasing filter order,

but very slowly.

Capacitors or inductors are also absorbed using cookbook bandpass filter topologies. The simplest form also requires equal termination resistance. Bandpass filters absorb a much more reactive load at the expense of reduced bandwidth. For example, a fractional bandwidth of 10%, or $bw = 0.1$, allows absorption of ten times larger components as seen in Eqs. 59 and 60. Bandpass filters also support series capacitors and shunt inductors at the load.

$$F_{\max} = \frac{bw}{2\pi g RC_{\text{series}}} \quad (61)$$

$$F_{\max} = \frac{bw \times R}{2\pi g L_{\text{shunt}}} \quad (62)$$

For example, suppose we wish to match a 50 ohm load with series capacitance of 20 pF to 20 dB return loss from 80 to 120 MHz using a three-section Chebyshev bandpass filter. What is the minimum value of series capacitance that can be absorbed? Using Eqs. 2 and 4 we find that the required passband ripple is 0.0432 dB. The final g -value for a three-section, 0.0432 dB ripple Chebyshev is 0.852. When using an L-C filter, the center frequency is found geometrically. That is,

$$F_{\max} = \sqrt{80 \times 120} = 97.98 \text{ MHz} \quad (63)$$

rather than 100 MHz. Therefore $bw = 40/97.98 = 0.408$. From Eq. 61 we see that $C_{\text{series}} = 15.6$ pF. Therefore, a series load capacitor of 15.6 pF or larger may be absorbed so the 20 pF series capacitance of the load may be absorbed. Given in Figure 15 are the schematic and responses of this matching network. The 70 pF network capacitor and the 20 pF load capacitors in series form the 15.6 pF capacitor required by the filter. As you can see, the line of distinction between filters and matching networks is not always clear.

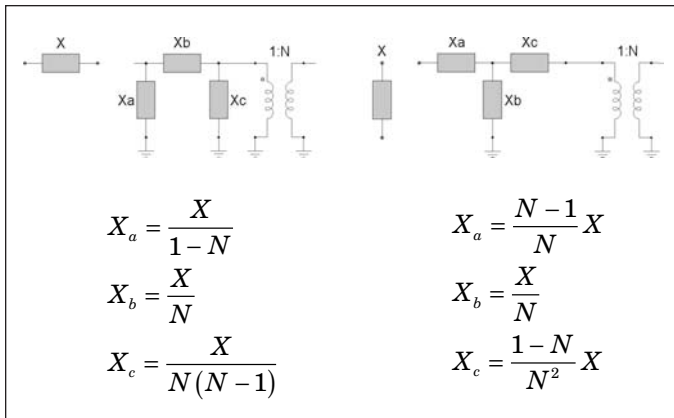

Figure 16 · Series Norton transform (left) and shunt Norton transform (right).

The Norton Transform

A great source of yang is the Norton transform. This underutilized transform is useful for a wide range of matching and filter applications [7]. There are two forms as shown in Figure 16, Norton’s first, or series transform, and his second, or shunt transform. These transforms convert a series or shunt reactor into three reactors and a transformer. The transformer turns ratio, N , is equal to the square root of the impedance ratio and it may be either greater or less than 1. Notice from the formula that one of the three reactors is always negative. Why would we be interested in a transform that converts one component into two positive valued components, one negative component and a transformer? It seems like a very poor trade. The yang is hidden in the details!

To design a matching network, I’ll start with the conventional cookbook three-section bandpass filter given in Figure 15. First, swap inductor L_2 and capacitor C_2 . This has no effect on the response. Next, the Norton shunt transform is applied to C_2 using $N = 0.408$. Ultimately, this steps 50 ohms up to 300 ohms. The resulting schematic is given at the top in Figure 17. The bottom schematic is after C_1 and the negative capacitor C_{2a} are combined and the transformer is shifted to the right and is absorbed by increasing the load resistance. For wider bandwidth using higher order filters, the Norton transform should be applied to as many nodes as possible. To step the impedance up on the right, the shunt Norton requires a series capacitor to the left of the shunt capacitor. In Figure 15 note that this occurs once in this three-section bandpass. In higher order filters it will occur more often. The intermediate impedances, and therefore the transformer turn ratios, are defined by Eq. 53 where N is the number of applied Norton transforms. The Norton technique for matching is reasonably economic. In other words, good bandwidth is achieved with a minimum number of elements.

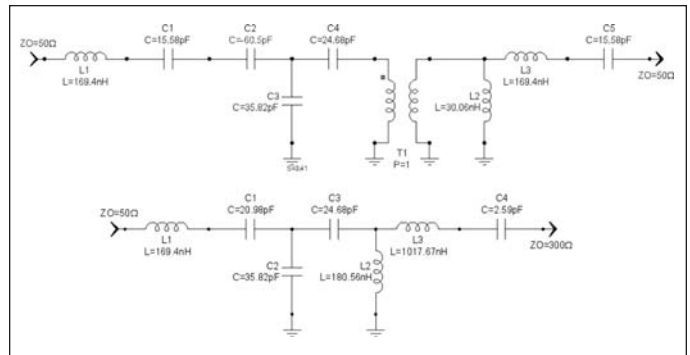

Figure 17 · Shunt Norton transform applied to capacitor C_2 in Figure 15 (top) and after absorbing C_{2a} into C_1 and transferring the transformer to the load (bottom). Notice the output load resistance has changed.

Reactance Absorption using Filters: Unequal Resistance

Once the load resistance is transformed, the techniques described in the section Reactance Absorption using Filters: Equal Resistance may be used to handle reactive loads. For example, in Figure 17 you can see that series inductors less than 1017 nH or capacitors greater than 2.6 pF can be absorbed. By using initial filters with a parallel last section, shunt inductors and capacitors are absorbed. I have therefore described procedures for the exact design of broadband matching networks for resistive or complex loads. Mastering the use of Norton transforms requires practice but the effort is worthwhile. The S/Filter module in GENESYS includes convenient routines for learning and using the Norton and many other network transformations [3].

Determining the Load Type

Knowledge of the nature of the load is required to select a matching network that can absorb the load reactance. Consider Figure 18 with the impedance of five different loads plotted vs. frequency on a Smith chart. The brown trace at the lower right is on the bottom half of the chart so it is capacitive. The reactance ranges from a normalized 1.0 to 2.8, or -50 to -140 ohms on a 50 ohm chart while the resistance is constant. This load is a capacitor in series with 120 ohms resistance. A matching network with a series capacitor smaller in value than the load capacitance could be used to absorb the load reactance. The green arc lies on a circle whose left side is tangent to the left end of the real axis. This circle is constant conductance on an admittance Smith chart. This arc is in the top half of the Smith chart so the load is inductive. It intersects the real axis at 0.5 so the load is 25 ohms in parallel with an inductor.

The blue and magenta arcs intersect the real axis. All arcs for positive values of inductors, capacitors and trans-

mission line length rotate clockwise on the chart with increasing frequency. The blue arc is on a circle of constant resistance and it is capacitive at low frequency and inductive at high frequency. It is a series L-C in series with constant 25 ohms resistance. A matching network for this load could end with a series L-C with L larger than the load and C smaller than the load, or it could end with the load being the final series resonator in a band-pass filter with alternating series and parallel resonators. The magenta arc is on a circle of constant conductance and it is inductive at low frequency and capacitive at high frequency. It is a parallel L-C in shunt with 100 ohms resistance. A matching network and corresponding responses for this load are given in Figure 19. This network is a conventional five-section bandpass filter that was designed so that the final resonator equaled the load's parallel L-C. Also, using a Norton transform, the center shunt capacitor was transformed into two capacitors, C3 and C4, to step the 50 ohm design impedance of the filter up to 100 ohms to equal the load resistance.

III-Behaved Loads

The red trace in Figure 18 is more interesting. It is modeled data for a 9.24 meter tall, 0.3 meter diameter monopole antenna tower mounted over ground. At low frequency it is capacitive. With increasing frequency it intersects the real axis at 35 ohms, it becomes inductive and then intersects the real axis at 400 ohms. At high frequency it is again capacitive. It is generally parallel to circles of constant resistance at the first resonance and parallel to circles of constant conductance at the higher frequency resonance. As is typical with monopole antennas, it has two resonances, a series resonance at 6.75 MHz followed by a parallel resonance at 14.25 MHz. The double resonance, and the fact that the resistance ranges from 34.4 ohms at series resonance to 405 ohms at parallel resonance makes this load difficult to match. In fact, attempting to match this load manually using an automated Smith chart program or a modern simulator with

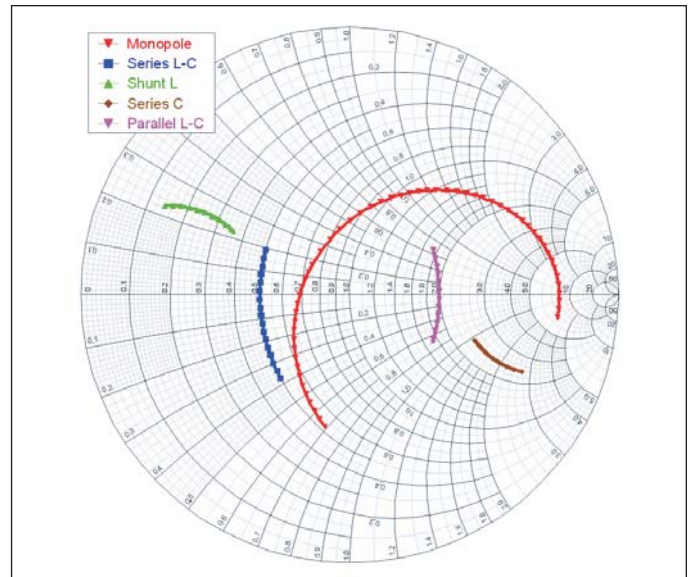

Figure 18 · Various types of loads plotted vs. frequency on a Smith chart.

optimization would be ineffective.

To match this antenna from 7 to 14.35 MHz I used the L-C Bandpass algorithm in the Impedance Match module of GENESYS. This algorithm finds an appropriate topology and computes element values based on user specified frequency limits and the network order. This algorithm uses four general automated steps. First, a best-fit RLC model is determined for the load. The algorithm then finds the poles and zeros of the matching network using a Chebyshev approximation [8,9]. A network is then synthesized using a continued-fraction expansion. The first three steps are very effective at finding the correct topology and in dealing with reactive loads. It is not particularly effective in transforming the resistive component of the match. Therefore, as the fourth step, the user launches an optimization that has been pre-defined by the algorithm. This four-step process is extremely effective in

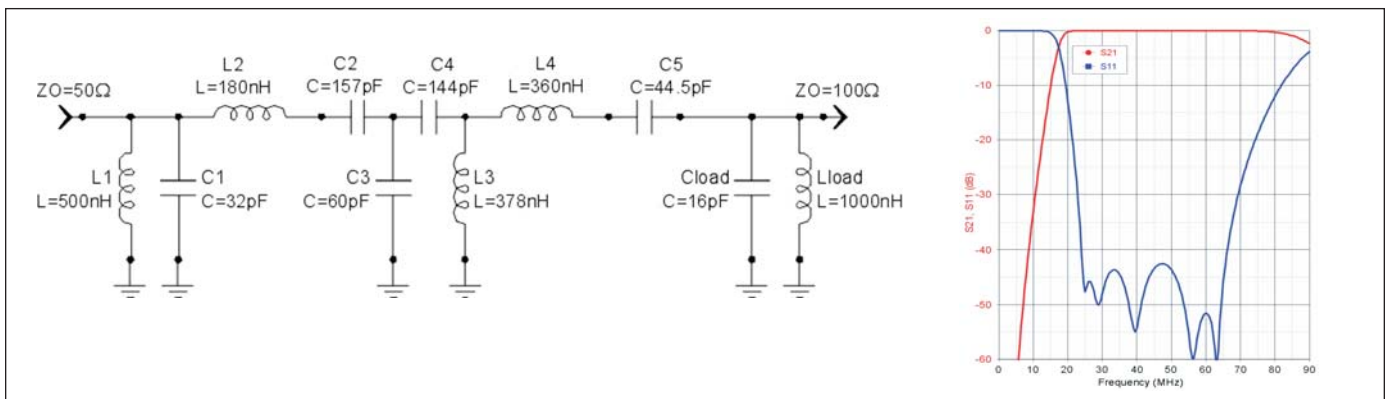

Figure 19 · A matching network for the parallel resonator load plotted in magenta in Figure 18 (left) and the corresponding responses (right).

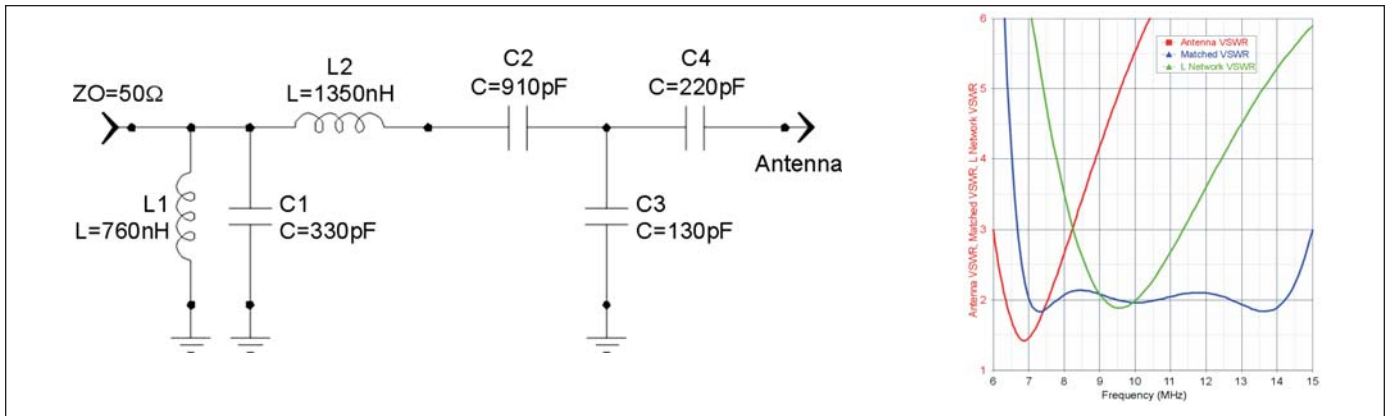

Figure 20 · Six element network designed to match the monopole antenna from 7 to 14.3 MHz (left) and the resulting VSWR plotted on the right (blue). Also plotted are the original monopole VSWR (red) and the monopole matched with a single L network (green).

dealing with ill-behaved loads.

On the left side of Figure 20 is a six-element matching network designed by this algorithm for the monopole antenna. Plotted in blue on the right is the resulting VSWR maintained at roughly 2:1 from 7 to just over 14 MHz. The original antenna VSWR is plotted in red. The resistance at the series resonance is close to 50 ohms and the raw VSWR is quite good. But the resistance at parallel resonance is high and the VSWR is poor. Plotted in green is the resulting VSWR with a simple L-network that successfully centered the frequency but it has poor bandwidth and the VSWR at the desired band edges is over 5:1.

Summary

I had two goals in this tutorial series on matching. First, I introduced many important concepts in matching to help you grasp the underlying objectives in matching network design. Second, I provided formula and techniques for the practical design of many types of both L-C and distributed networks. Not included were techniques applicable to transmission line transformers. The later are particularly effective in dealing with resistive loads in the HF and VHF frequency range. This topic is well covered by Sevick [10,11,12].

Author Information

Randall Rhea is a consultant to Agilent Technologies. He received a BSEE from the University of Illinois and an MSEE from Arizona State. He worked at the Boeing Company, Goodyear Aerospace and Scientific-Atlanta. He is the founder of Eagleware Corporation which was acquired by Agilent Technologies in 2005 and Noble Publishing which was acquired by SciTech Publishing in 2006. He has authored numerous papers and tutorial CDs, the books *Oscillator Design and Computer*

Simulation and HF Filter Design and Computer Simulation and has taught seminars on oscillator and filter design.

References

1. P. Smith, *Electronic Applications of the Smith Chart*, 2nd edition, 1995, SciTech/Noble Publishing, Raleigh, North Carolina.
2. G. Parker, *Introduction to the Smith Chart*, (CD-ROM tutorial), 2003, SciTech/Noble Publishing, Raleigh, North Carolina.
3. Agilent Technologies, EEsof EDA Division, Santa Rosa, CA. www.agilent.com/find/eesof
4. G. Matthaei, L. Young, and E.M.T. Jones, *Microwave Filters, Impedance Matching Networks and Coupling Structures*, Artech House, Dedham, MA, 1967/1980.
5. R. Rhea, *Practical Issues in RF Design* (3 set CD-ROM tutorial), 2003, SciTech/Noble Publishing, Raleigh, North Carolina.
6. R. M. Fano, "Theoretical Limitations on the Broadband Matching of Arbitrary Impedances," *Journal of the Franklin Institute*, January 1950.
7. R. Rhea, *Filter Techniques* (3 set CD-ROM tutorial), 2003, SciTech/ Noble Publishing, Raleigh, North Carolina.
8. R. Levy, "Explicit Formulas for Chebyshev Impedance-Matching Networks," *Proc. IEEE*, June 1964.
9. T.R. Cuthbert, Jr., *Circuit Design Using Personal Computers*, John Wiley, New York, 1983.
10. J. Sevick, *Transmission Line Transformers*, 4th ed., 2001, SciTech/ Noble Publishing, Raleigh, North Carolina.
11. J. Sevick, "Design of Broadband Ununs with Impedance Ratios Less Than 1:4," *High Frequency Electronics*, November, 2004.
12. J. Sevick, "A Simplified Analysis of the Broadband Transmission Line Transformer," *High Frequency Electronics*, February, 2004.