

Finding the Lumped Element Varactor Diode Model

By George H. Stauffer
Rockwell Collins

Here is a method for using measured data to accurately describe the behavior of a varactor diode, providing the CAD simulator with a model that corresponds to actual device performance

An accurate model for the varactor diode is necessary when designing a voltage controlled oscillator (VCO) using CAD simulation. In order to predict tuning range, start up gain, and phase noise, the resonator must be accurately modeled over the frequency range of the oscillations. The varactor diode used for tuning has a predominant effect on the Q , phase noise and tuning range of the resonator. If the varactor model is inaccurate, the results of the most elaborate computer simulation will be misleading and the oscillator, when built, may have disappointing performance.

Figure 1 shows a commonly used lumped element varactor diode model. The values for package inductance and capacitance, L_p and C_p shown are typical for an 0805 surface mount part. The values for junction capacitance, C_j and Q are supplied by the manufacturer and are almost always specified at a low frequency, usually 50 MHz, and a bias voltage of -4 Volts. Q is defined by $Q = 1/\omega C_j R_s$. This formula can be used to calculate the series resistance R_s of the varactor model at the measured frequency, however at microwave frequencies additional losses often result in a significantly higher value for R_s . Also, R_s decreases with increasing bias voltage as the width of the depletion region around the PN junction increases, reducing the length of the conductive path through the bulk semiconductor material surrounding the junction.

Varactor Diode Model

Figure 1 shows a commonly used lumped element varactor diode model. The values for package inductance and capacitance, L_p and C_p shown are typical for an 0805 surface mount part. The values for junction capacitance, C_j and Q are supplied by the manufacturer and are almost always specified at a low frequency, usually 50 MHz, and a bias voltage of -4 Volts. Q is defined by $Q = 1/\omega C_j R_s$. This formula can be used to calculate the series resistance R_s of the varactor model at the measured frequency, however at microwave frequencies additional losses often result in a significantly higher value for R_s . Also, R_s decreases with increasing bias voltage as the width of the depletion region around the PN junction increases, reducing the length of the conductive path through the bulk semiconductor material surrounding the junction.

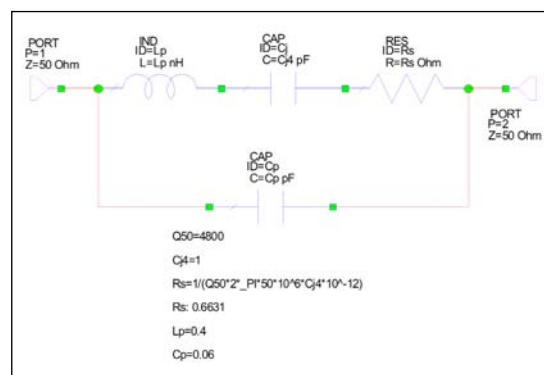

Figure 1 · Lumped element model of varactor diode using manufacturer's specifications. R_s is calculated from $Q = 1/\omega C_j R_s$ at 50 MHz.

R_s is sometimes assumed to be constant with reverse voltage and frequency in order to simplify use of the model. A much more accurate picture can be had by measuring the diode close to operating conditions and then choosing values for the lumped element model based on these measurements. Two important operating conditions are the frequency at which the diode is to be used and mounting method. One way would be to simply mount the diode at the end of a 50 ohm transmission line and measure S_{11} of the two-terminal diode using a network analyzer. However, unless extreme care is taken to make a very accurate S_{11} calibration at the point where the diode is mounted, the calculated real part of the diode impedance, R_s may have a large error because the impedance of the diode is close to the edge of the Smith chart. A more accurate network analyzer measurement is made by first matching the diode to 50 ohms

VARACTOR MODEL

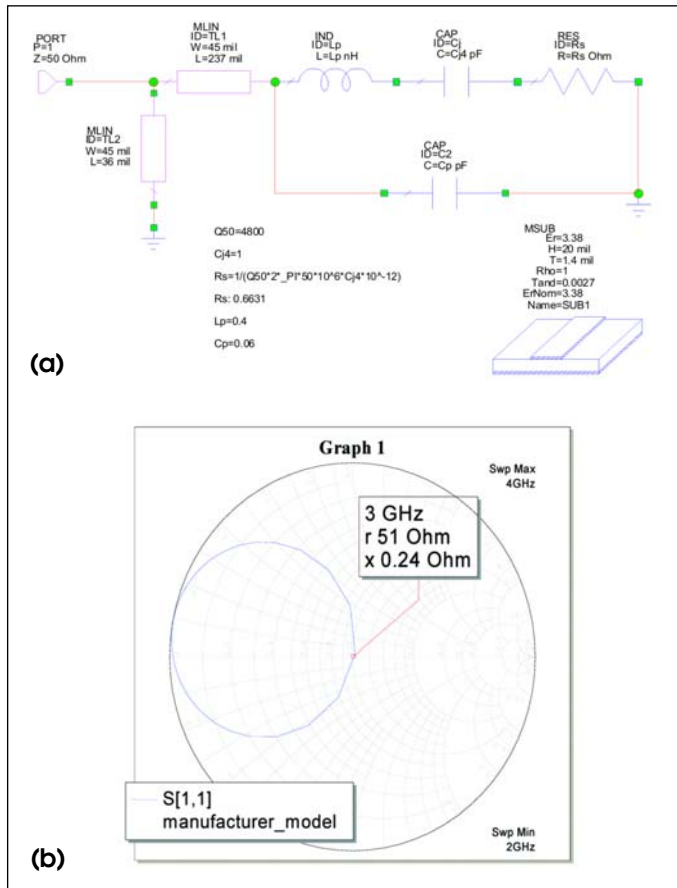

Figure 2 · Varactor diode model matched to 50 ohms using microstrip tapped line (a); S_{11} from 2 to 4 GHz (b).

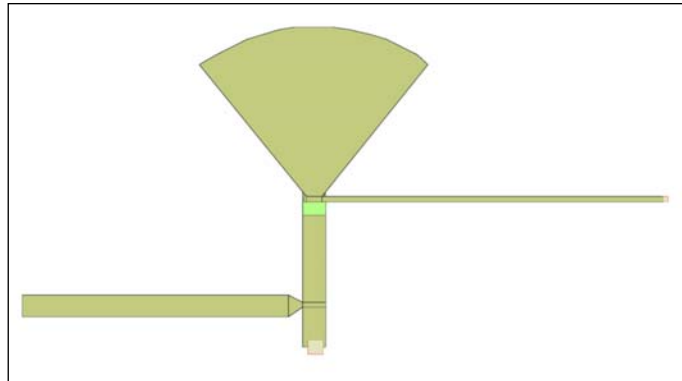

Figure 3 · Microstrip test fixture with tapped line and bias circuit.

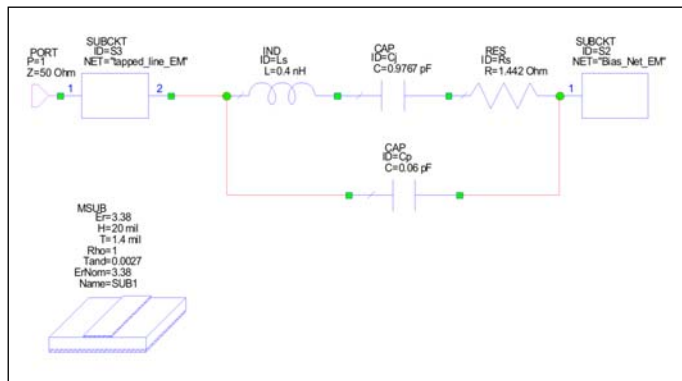

Figure 4 · Tapped line and bias network models from EM simulation connected to diode model.

at the frequency of interest. A matching structure which uses only microstrip elements is preferable because it can be analyzed quite accurately using an EM simulator and its effect in the circuit can then be accounted for when calculating the model parameters.

An Accurate Model is Required for VCO Design

A recent 3 GHz VCO design required that the resonator circuit be optimized for best phase noise and tuning range, yet also allow for adequate production margin. A suitable varactor diode was selected based on the required range of capacitance variation. In order to begin to accurately characterize the diode, the model with values supplied by the manufacturer was matched at 3 GHz

using a microstrip network as shown in Figure 2a. The swept frequency response from 2 to 4 GHz describes a loop on the Smith chart as shown in Figure 2b. At 3 GHz the resonance loop passes through the center of the Smith chart indicating critical coupling.

From this point it is a simple matter to add microstrip elements to produce a practical circuit to be used as a test fixture. The layout is shown in Figure 3 and includes a biasing network consisting of a radial stub and a high impedance quarter wave line. At 3 GHz the bias network is an RF short at the cathode terminal.

The S-parameters of the bias network and the tapped line are calculated individually using an EM simulation program and the results are used in the measurement fixture

schematic in Figure 4.

This layout was reproduced on 20 mil Rogers 4003 board, and this 2 x 2 inch board was mounted on a test fixture block, shown in Figure 5. The network analyzer was calibrated at the coax connector, with the reference plane brought to the edge of the board using a 16.7 ps port extension. The S_{11} measurements were then made at bias voltages over a 0-20 V range while sweeping from 2 to 4 GHz.

The S_{11} measurements were saved and imported into the CAD program. After these measurements, all that remains to be done is to adjust C_j and R_s of the model of Figure 4 so that the measured S_{11} agrees with S_{11} calculated from Figure 4 over the entire 2 to 4 GHz frequency range for each value of bias

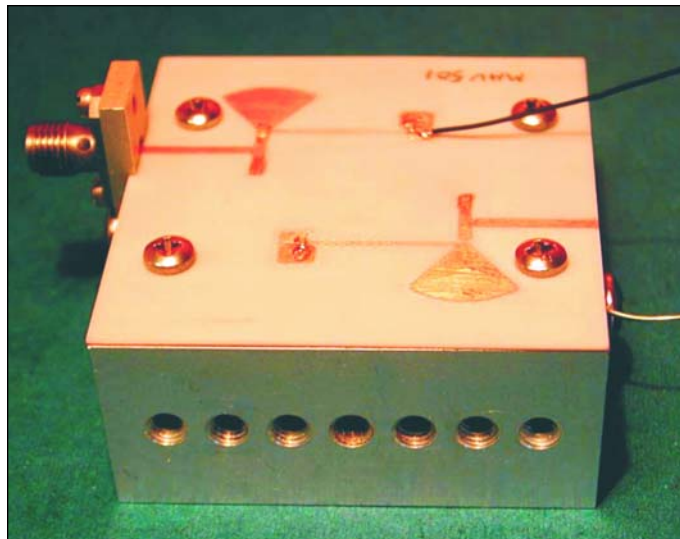

Figure 5 · Test fixture with diode mounted for S_{11} measurement.

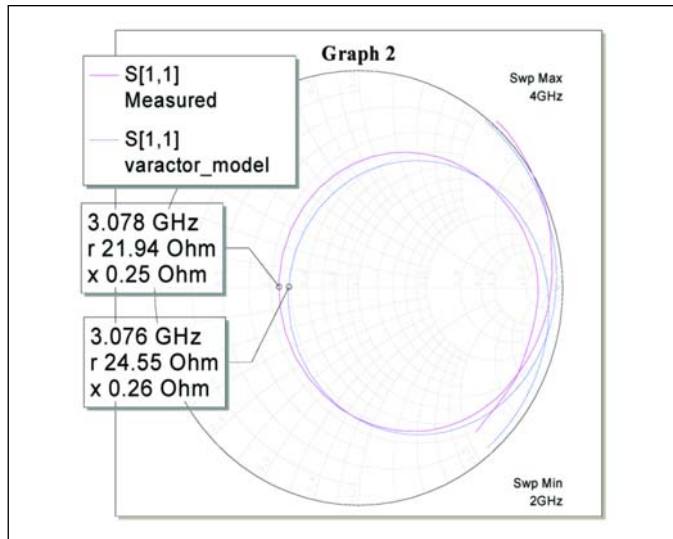

Figure 6 · Measured and modeled response at $V = -4$ V.

voltage. The CAD program employs a built in optimizer to accomplish this task. The results of one such optimization for a bias voltage of -4 V are shown in Figure 6 where the measured and modeled values are seen to match closely.

A graph of the results after optimizing the model to the measured data at all bias voltages is shown in Figure 7. Here C_j and R_s are plotted versus bias voltage. Also shown is the capacitance variation computed using the equation for the junction capaci-

tance of an abrupt junction diode :

$$C_j(V) = \frac{C_j(0)}{\left(1 + \frac{V}{.75}\right)^{0.5}} \quad (1)$$

Q of the varactor at 3 GHz calculated from measured values of R_s and C_j using $Q = 1/\omega C_j R_s$ is shown plotted versus bias voltage in Figure 8.

Figure 9 shows the model derived from the measured data. C_j is determined from equation (1) and R_s calcu-

lated from equation (2), a polynomial with coefficients chosen to fit the R_s vs. bias voltage curve in Figure 7:

$$R_s = 4.025 \times 10^{-5} v^4 - 1.84 \times 10^{-3} v^3 + .029 v^2 - .205 v + 2.056 \quad (2)$$

Resonator Design with the Accurate Diode Model

The actual resonator used in the 3 GHz VCO is a shorted microstrip line shunted at the input by the var-

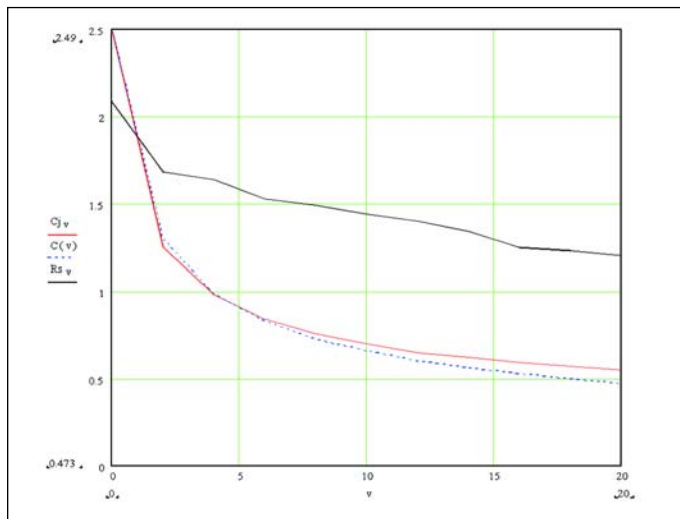

Figure 7 · C_j and R_s computed from model and the calculated value of $C(v)$.

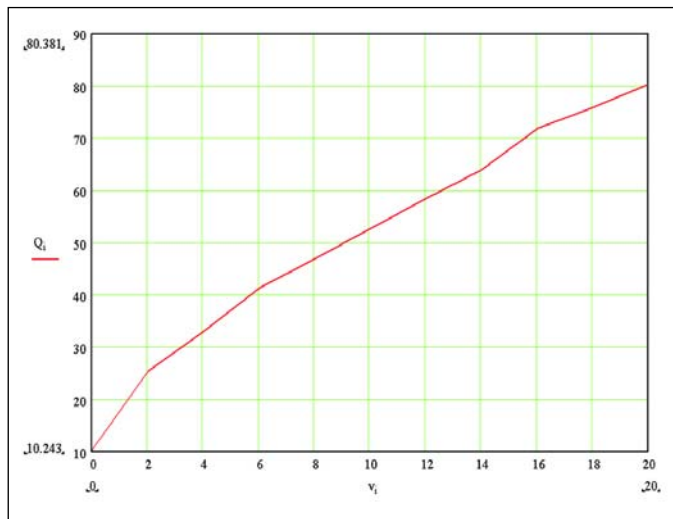

Figure 8 · Varactor Q versus bias voltage at 3 GHz.

VARACTOR MODEL

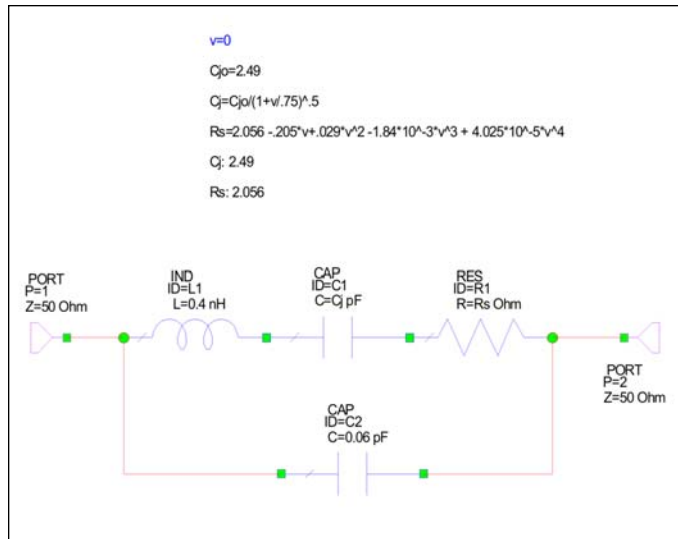

Figure 9 · Derived model at 3 GHz with equations for C_j and R_s as functions of V .

actor diode and coupled to the active device of the VCO by a small value series capacitor, as diagrammed in Figure 10a. As shown in Figure 10b, the calculated resonator loss using the derived model from Figure 9 is low enough at resonance for oscillations to start when connected to one port of an unstable active device having a reflection gain of 6 dB or more over the frequency range from 2.8 to 3.2 GHz.

Conclusion

At a bias voltage of -4 VDC, R_s first calculated from $Q = 1/\omega C_j R_s$ using the manufacturer's value of Q at 50 MHz was 0.67 ohms. Compare this optimistic value to the more realistic value of $R_s = 1.64$ ohms derived from the measurements described at 3 GHz. The first value would have resulted in an overly optimistic design and the engineer would have been left wondering where it had all gone wrong. A model that accurately behaves like the actual device gives much more confidence in the simulated results and may avoid disappointment when the hardware is built and tested.

References

1. D. Johnson, "Tuning Diode Design Techniques," Motorola Application Note AN551.
2. "Varactor SPICE Models for RF VCO Applications," Application Note APN1004, Alpha Industries.

Author Information

George Stauffer is a Principal Engineer at Rockwell Collins Government Systems, Germantown, MD. His primary interest is microwave synthesizer design. He can be reached by e-mail at: ghstauff@rockwellcollins.com

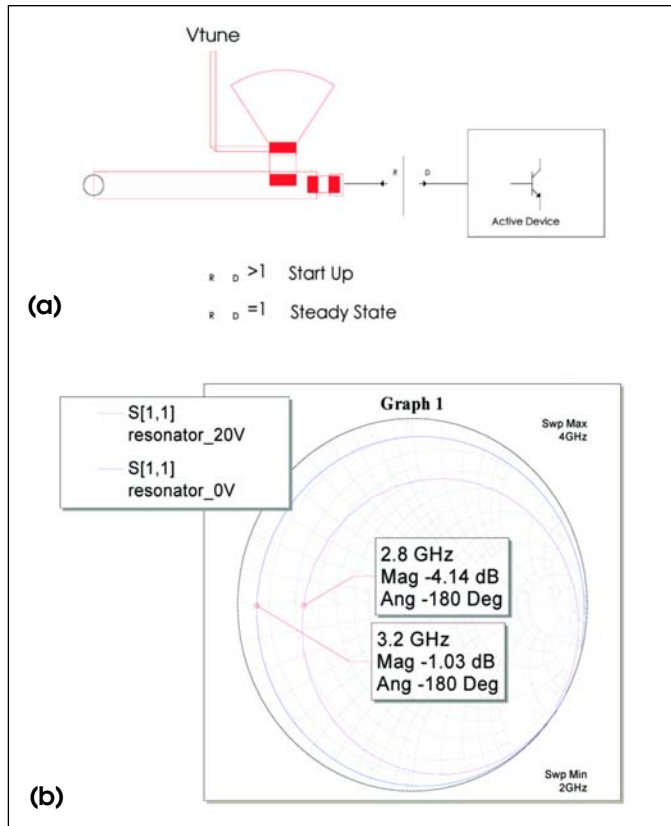

Figure 10 · Layout of 2.8-3.2 GHz resonator with requirements for start-up and steady state oscillations (a), and the resonance loops at 0 and 20 VDC tuning voltages calculated from the improved diode model (b).

CALL FOR TUTORIAL ARTICLES

High Frequency Electronics includes a tutorial article in each issue. These are targeted to both new engineers and those who have been working in other areas of specialization. We are accepting proposals for articles on following topics for publication in these 2004 issues:

- March: Personal Area Networks (PANs)
- April: Power Amplifier Linearization
- May: Filter Specifications
- September: Balanced Circuits
- October: Optical Detectors and Preamps

Send an abstract or outline by e-mail to: editor@highfrequencyelectronics.com. If you have questions, send them by e-mail or telephone to Gary Breed, Editorial Director, at 608-845-3965.